

Digital electropneumatic positioner



Type 8792 can be combined with...



Yoke type actuators



Rack/pinion actuators

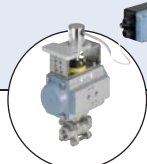

Rack/pinion actuators with remote positioner



Process control valve with remote positioner



Hygienic process control valve with remote positioner

- Compact and robust design
- Easy to start using tune function
- Integrated diagnostic functions for valve monitoring (optional)
- Dynamic positioning system with no air consumption in controlled state
- Profibus DPV1 or DeviceNet (optional)

The robust and compact positioner is designed to standardisation acc. to IEC 534-6 or VDI/VDE 3845 for assembly with linear and rotary actuators. In addition, the remote version with the displacement position sensor can be combined with Bürkert process control valves. The digital electropneumatic positioner SideControl can be operated with the usual current and voltage standard signals and can also be equipped with the fieldbus interface PROBUS DPV1.

The Positioner is equipped with additional diagnostic functions to monitor the state of the valve. Through status signals, valve diagnostic messages are transmitted according to NAMUR NE 107 recommendations and recorded as history. With the diagnosis, the operating conditions of the control valve can be monitored. This allows planned maintenance and optimises plant availability.

Operation occurs via the external operation and display module with a backlit graphical display. The user operation is very simple and clear, identical to the Bürkert positioner or process controller TopControl, Type 8692/8693.

The pilot valve system can be used equally for single and double-acting drives. It is characterised by a defined safety feature in case of failure of the electrical or pneumatic power supply and possesses an enormous air capacity range with pressure supply up to 7 bar.

Technical data	
Material	
Body	Aluminium plastic-coated
Seal	EPDM, NBR, FKM
Operating voltages	24 V DC +/- 10%
Residual ripple	Max. 10%
Setpoint setting	0/4 to 20 mA and 0 to 5/10 V
Input resistance	0/4 to 20 mA: 180 Ω 0 to 5/10 mA: 19 k Ω
Analogue feedback	4-20 mA, 0-20 mA 0-10 V, 0-5 V
Binary input	Galvanically isolated, 0-5 V = log "0", 10-30 V = log "1"
Binary output	2 Outputs (optional), galvanically separated
Current limit	100 mA, Output will be synchronised when overloaded
Control medium	Neutral gases, air DIN ISO 8573-1
Dust concentration	Class 5 (<40µm particle size)
Particle density	Class 5 (<10mg/m ³)
Pressure condensation point	Class 3 (<-20°C)
Oil concentration	Class 5 (<25mg/m ³)
Ambient temperature	0 to +60°C
Pilot air ports	Threaded ports G 1/4
Supply pressure	1.4 to 7 bar ^{1) 2)}
Air supply filter	Exchangeable (aperture size ~0.1mm)
Actuator system	Single and double-acting to 150 l _N /min.
Air capacity	50 l _N /min (with 1.4 bar ²⁾) for aeration and ventilation 150 l _N /min (with 6 bar ²⁾) for aeration and ventilation (Q _{Nn} = 100 l _N /min (acc. to the definition with decrease in pressure from 7 to 6 bar absolute)
Position detection module	Potentiometer, max. angle 180°
Stroke range valve spindle	Min. 30° on the rotary shaft, depending on lever
Installation	As required, display above or sideways

¹⁾ The supply pressure has to be 0.5-1 bar above the minimum required pilot pressure for the valve actuator

²⁾ Pressure specifications: Overpressure with respect to atmospheric pressure

continued on next page

Technical data, continued

Technical data	
Type of protection	IP65 and IP67 acc. to EN 60529 (NEMA4x in preparation)
Power consumption	< 5 W
Electrical connection	M12, 8-pin/4-pin; M8, 4-pin
Multipole connection	2xM20x1.5 (cable Ø 10mm) on screw terminals (0.14-1.5 mm ²)
Cable gland	
Remote version	1xM12x1.5 (cable Ø 3 to 6.5mm)
Bus communication	Profibus DPV1 or DeviceNet
Protection class	3 acc. to VDE 0580
Type of ignition protection	II 3 G nA II B T4 II 3 D tD A22 T135°
Conformity	EMC directive 2004/108/EC
CSA approval information	Class 3221 82-VALVES - Actuators - Certified to US standards Class 3221 02-VALVES - Actuators
Product category code	
Considered standards	CAN/CSA-C22 2 No. 139 UL 429
CSA trademark	 C US

Technical data - Linear Remote Position Sensor (ELEMENT, CLASSIC)	
Electrical connection	1xM16x1.5 (cable Ø 5-10mm) on terminal screws (0.14-1.5mm ²)
Cable gland	
Connection cable length	10 m
Operating voltage	24V DC ± 10 %
Power consumption	< 0.3 W
Sensor measurement range	3 to 45 mm (Stroke range valve spindle)
Actual position signal	digital (RS485)
Ambient temperature	-25 to +80°C
Protection class	3 acc. to VDE 0580
Type of protection	IP65 and IP67 acc. to EN 60529 (NEMA4x in preparation)
Type of Ignition protection	II 3D Ex tc IIIC T135°C Dc II 3G Ex nA IIC T4 Gc
Conformity	EMC directive 2004/108/EC
Approvals	cCSAus, cULus Certificate no. 238179

Technical data - rotative Remote Position Sensor (NAMUR)	
Electrical connection	2 m round cable (shielded)
Operating voltage	10 to 30V DC
Residual ripple	< 0.8W
Sensor measurement range	0° to 360°
Actual position signal	digital (RS485)
Ambient temperature	-25 to +80°C
Protection class	3 acc. to VDE 0580
Type of protection	IP65 acc. to EN 60529
Conformity	EMC directive 2004/108/EC
Approvals	UL (cULus) Certificate no. E226909

Technical data - Position feedback with proximity switches (Accessory)	
Electrical connection	M12, 4-pin
Output function	3-wire, normally open contact, PNP
Operating voltage	10 to 30 V DC
Residual ripple	≤ 10% U _{ss}
DC rated current	≤ 100 mA
Type of protection	IP65 and IP67
Protection class	3 acc. to VDE 0580
Conformity	EMC directive 2004/108/EC
Approvals	cCSAus

Note: The position feedback has two proximity switches which are independently adjustable via switch lugs.

Using a remote positioner the length of the control air pipes influences the dynamics and attainable accuracy of the position control loop. The length of the control air pipes therefore should be as short as possible.

Example of assembly variations of Positioner SideControl

Positioner SideControl Type 8792

	8792 NAMUR		8792 Remote	
Positioner 8792				
	Linear actuators IEC 534-6	Linear actuators IEC 534-6	Control valve system	Control valve system
	Rack/pinion actuators VDI/VDE 3845	Rack/pinion actuators VDI/VDE 3845	Type 2300 + Type 8798 Remote Position Sensor + Type 8792 Remote	Type 2702 + Type 8798 Remote Position Sensor + Type 8792 Remote
	Type 8805 + Type 8792	Type 8798 Sensor Remote NAMUR + Type 8792 Remote		

Assembly options

NAMUR Version

(Positioner with integrated position sensor, assembly acc. to NAMUR/IEC 534-6 and VDI/VDE 3845)

Assembly on rotary actuator



Description	Item no.
Adapter kit	787 338
Assembly bridge	770 294

Assembly on linear actuator

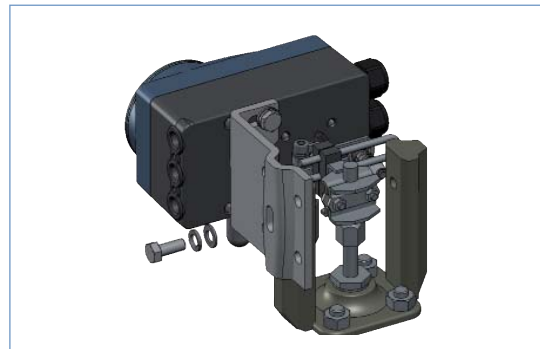

Description	Item no.
Adapter kit	787 215

Dimensions [mm]

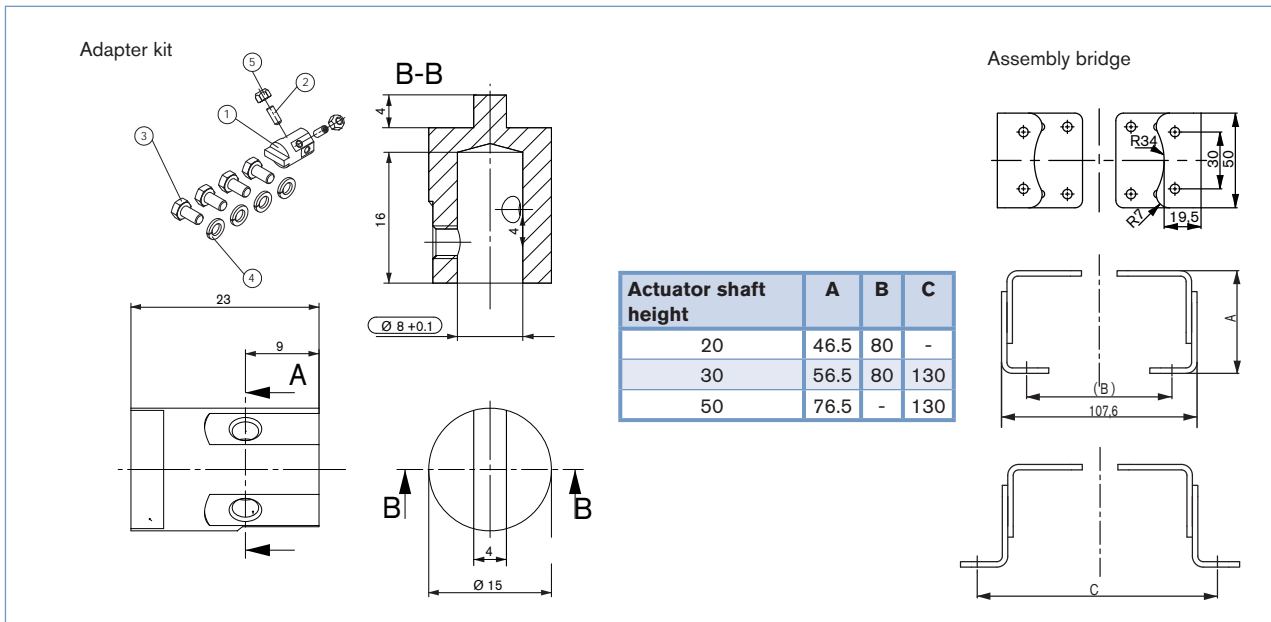

Position feedback with proximity switches
(upgrade feature for SideControl NAMUR)

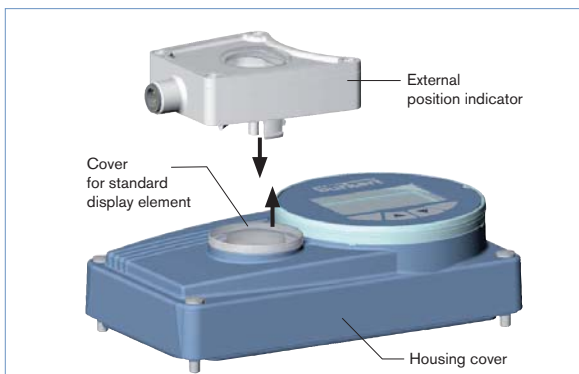

Description	Item no.
Position feedback	677 218

Assembly options *continued*

Remote version

(Displaced Positioner with external remote position sensor)

Assembly with accessory brackets

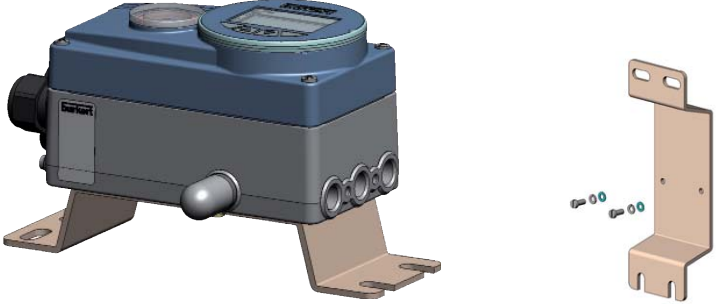

Description	Item no.
Assembly bracket for wall mounting	675 715

Dimensions [mm]

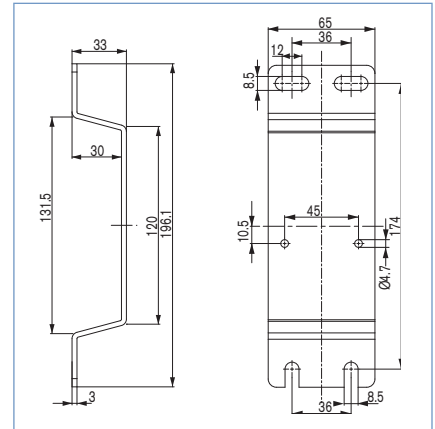

Assembly on DIN-Rail

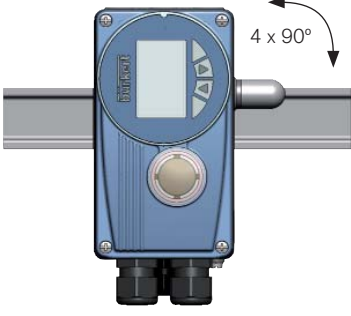

The adapter can be turned every 90° on the DIN-Rail

Description	Item no.
DIN rail assembly kit	675 702

Dimensions [mm]

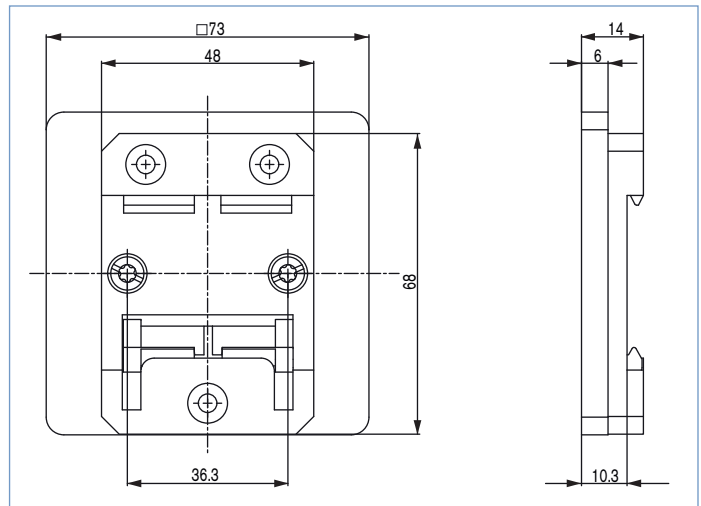

Assembly options *continued*

Remote version

(Remote position sensor for displaced Positioner)

Type 8798



Description	Item no.	
	Standard	ATEX II 3 GD
Remote Position Sensor		
Control valves CLASSIC Types 27xx	211 535	226 859
Control valves ELEMENT Types 23xx	212 360	226 860



Description	Item no.
Remote Position Sensor NAMUR	211 536

Dimensions

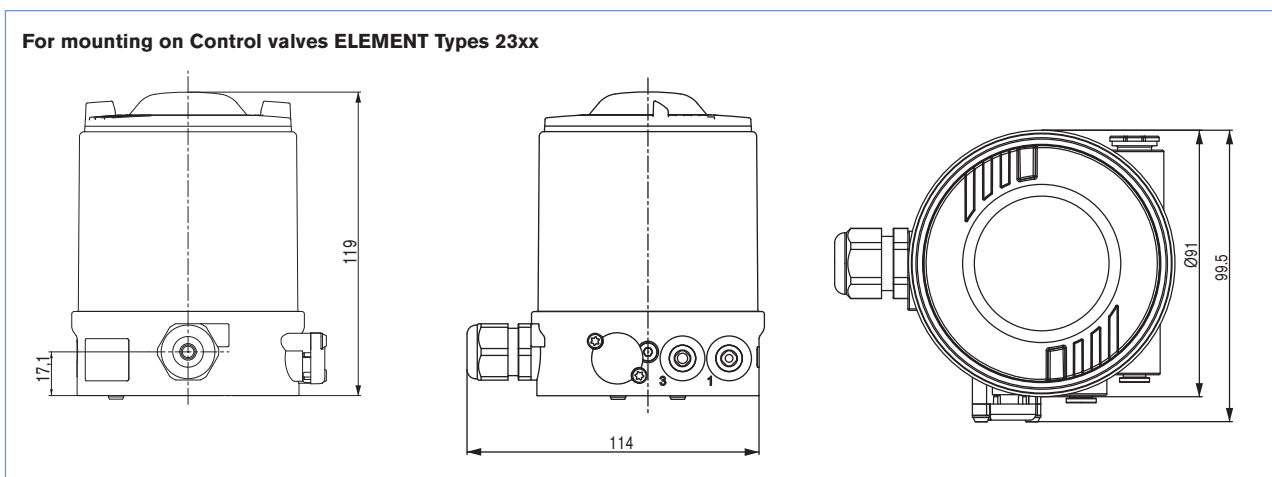
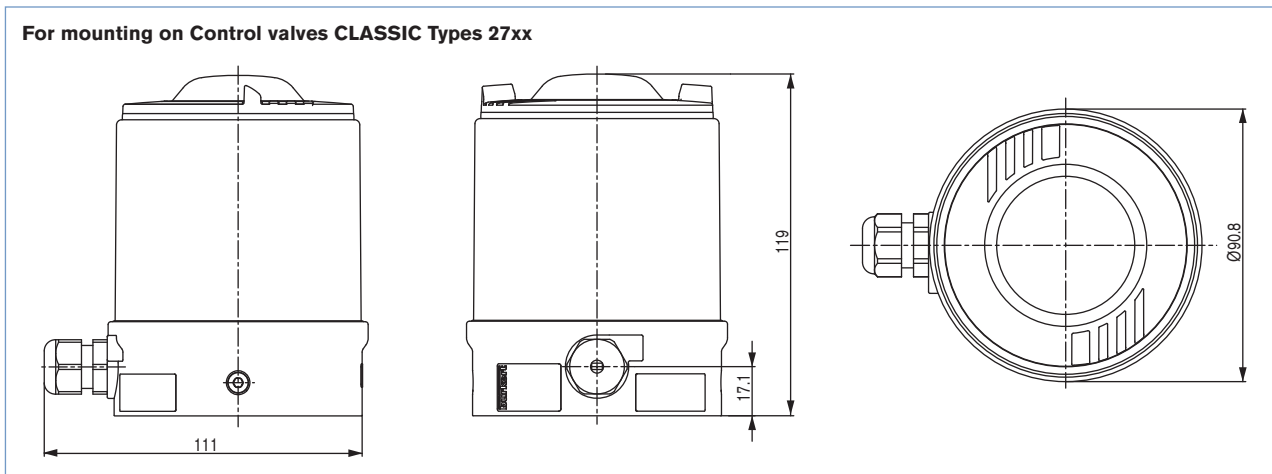

Dimensions

Mounting on control valves according to NAMUR (IEC 534-6 / VDI / VDE 3845)

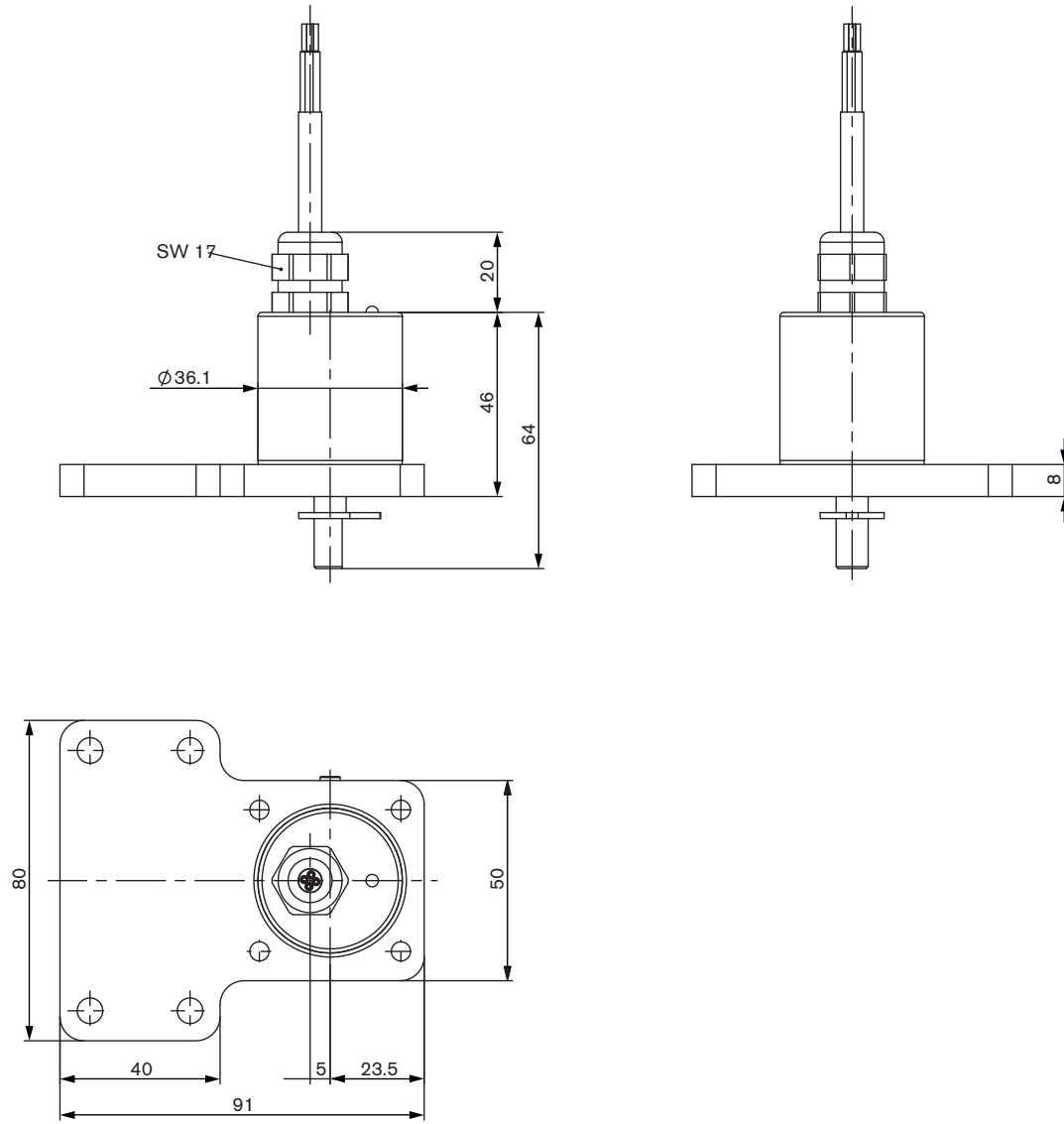

Ordering Chart (further version on request)

Positioner SideControl Type 8792

Assembly variations	Control function	Pilot valve system /Air capacity	Communication	Electrical connection	Analogue feedback	2 Binary outputs	Binary Input	Diagnostic functions*	ATEX II 3 GD	Item no.
NAMUR IEC 534-6 VDI/VDE 3845	Single and double-acting	Universal	No	Cable gland	no	no	yes			206 610
					no	yes	yes	yes		206 612
					yes	yes	yes	yes		206 611
				yes	yes	yes	yes	yes	226 842	
				Multipole	no	no	yes			206 613
					no	no	yes		yes	226 844
					no	yes	yes	yes		206 615
			yes		yes	yes	yes		206 614	
			Profibus DPV1	via Bus	no	yes			206 616	
				via Bus	no	yes		yes	226 845	
				via Bus	yes	yes	yes	yes	226 846	
			DeviceNet	via Bus	yes	yes	yes		206 617	
				no	no	yes			239 094	
			no	yes	yes	yes			239 095	

Assembly variations	Actuator size	Control function	Pilot valve system /Air Capacity	Communication	Electrical connection	Analogue feedback	2 Binary outputs	Binary Input	Diagnostic functions*	ATEX II 3 GD	Item no.
Remote	ELEMENT 70/90 CLASSIC 80/100	Single-acting	Low	no	Cable gland	yes	yes	yes	yes		224 870
						no	yes	yes	yes		224 871
	ELEMENT 130 CLASSIC 125-225	Single and double-acting	Universal			no	no	yes			206 623
						yes	yes	yes	yes		206 624
						no	yes	yes	yes		206 625

Assembly variations	Electrical connection	Item No.
Remote Position Sensor		Standard ATEX II 3 GD
CLASSIC Type 27xx	Cable gland - 10 m round cable	211 535 226 859
ELEMENT Type 23xx	Cable gland - 10 m round cable	212 360 226 860
NAMUR (rotative)	Cable gland - 2 m round cable (max. extension 10 m)	211 536

*see additional software functions parametrisable diagnostic functions on page 13

i Further versions on request



Approvals
Protection type: NEMA 4x
Remote ATEX Cat. 3

Ordering chart for accessories

Description	Item no.
Accessories for SideControl NAMUR	
Assembly bridge VDI/VDE 3845, stainless steel	770 294
Adapter kit VDI/VDE 3845, stainless steel	787 338
Adapter kit linear actuators IEC 534-6, stainless steel	787 215
Position feedback with proximity switches (optional upgrade feature) ³⁾	677 218

Accessories for SideControl Remote	
Bracket for wall mounting, stainless steel	675 715
DIN rail assembly kit, Aluminium/stainless steel	675 702
Adapter kit - remote sensor, ELEMENT Type 23xx control valves Actuator size Ø 70/90/130 mm	679 917
Adapter kit - remote sensor, CLASSIC Type 27xx control valves Actuator size Ø 80 mm	679 943
Actuator size Ø 100/125 mm	679 944
Actuator size Ø 175/225 mm	679 945
Sensor Puck (replacement part)	682 240

Standard Accessories	
USB Interface for serial communication	227 093
M12 socket, 8-pin, 2 m assembled cable	919 061
M12 socket, 8-pin, 5m assembled cable	919 267
M8 plug, 4-pin for binary outputs, without cable	917 131
Silencer G 1/4" (spare part)	780 780

* Related Communication software can be downloaded from www.buerkert.com (8792)

³⁾ External end position feedback for upgrading SideControl NAMUR

Connection options

Multi-pin connection

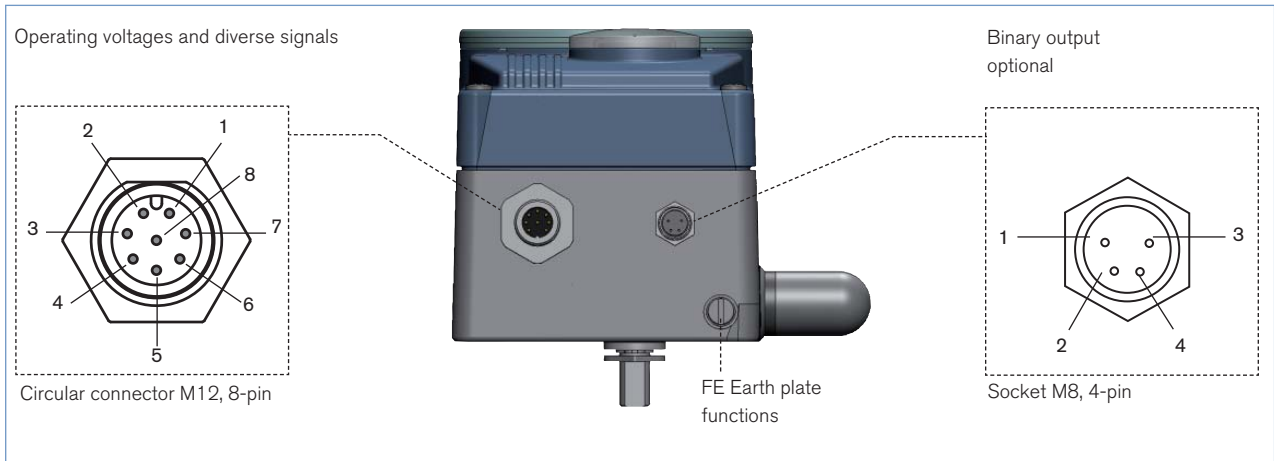

Circular connector M12 - 8-pin (Setpoint)

Pin	Configuration	External Circuitry / signal level
1	Setpoint + (0/4-20 mA or 0-5/10 V)	1 + (4-20 mA or 0-10 V) Complete galvanically separated
2	Setpoint GND	2 GND
3	GND	3 24 V DC ± 10% Max. Residual ripple 10%
4	+ 24 V	4 24 V DC ± 10% Max. Residual ripple 10%
5	Binary input +	5 + 0-5 V (log. 0) 10-30 V (log. 1)
6	Binary Output GND	6 GND

Optional analogue feedback

8	Analogue feedback +	8 + (0/4-20 mA or 0-5/10 V,) Complete galvanically separated
7	Analogue feedback GND	7 GND

Socket M8, 4-pin (only with Binary Output Option)

Pin	Configuration	External Circuitry / signal level
1	Binary Output 1	1 0-24 V
2	Binary Output 2	2 0-24 V
3	Binary Output GND	3 GND

Electrical connection Position feedback with proximity switches (accessory for upgrading)

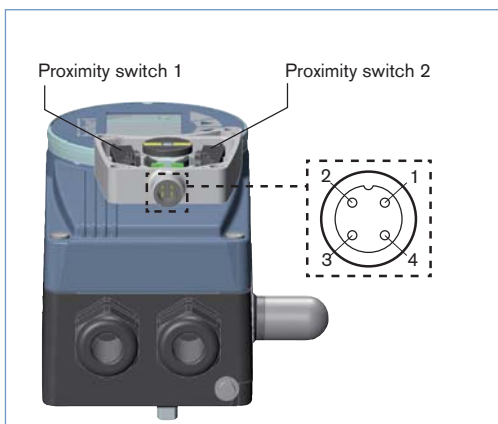

Pin	Config.	External circuit /signal level
1	Supply 10 ... 30 V	+10 V ... +30 V 1 10 ... 30 V
2	Switching output (NO) Proximity switch 1	+10 V ... +30 V 2 Open / 10 ... 30 V
3	GND	GND 3 GND
4	Switching output (NO) Proximity switch 2	+10 V ... +30 V 4 Open / 10 ... 30 V

Connection options, continued

Connection PROFIBUS-DP

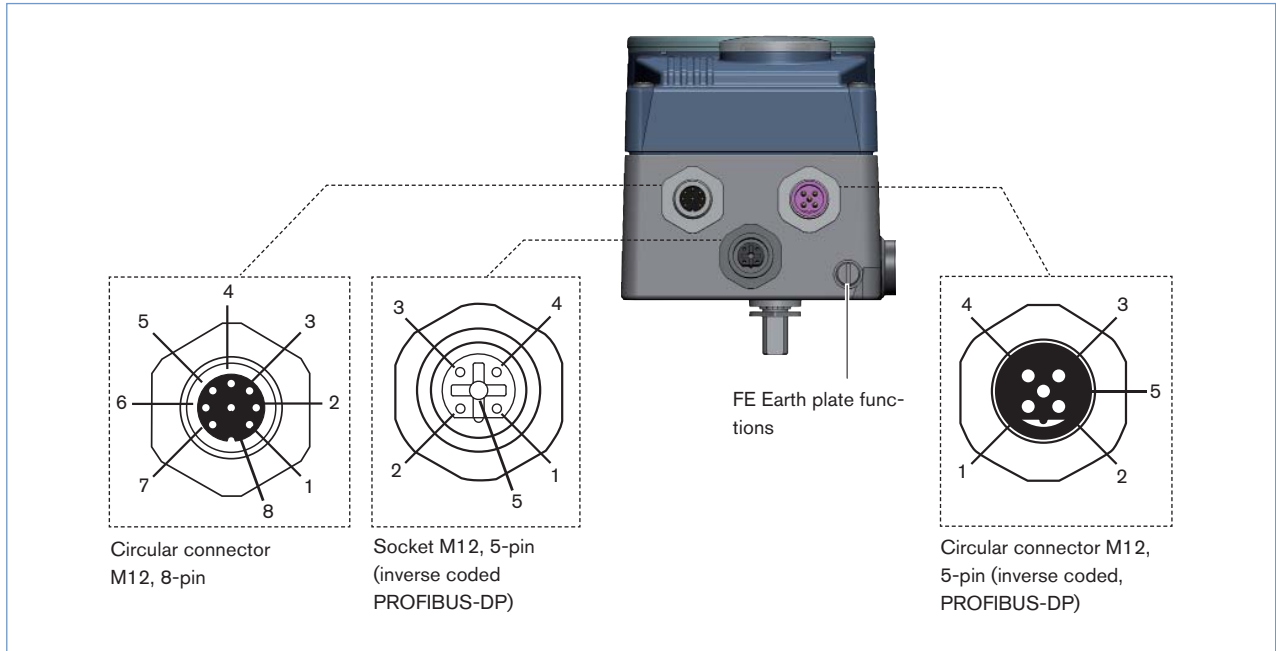

Operating voltages - Circular connector M12, 8-pin

Pin	Configuration	External Circuitry / signal level
1	Not configured	
2	Not configured	
3	GND	
4	+24 V	
5	Binary input +	
6	Binary input -	
7	Binary Output 1 (oriented at Pin 3)	
8	Binary Output 2 (oriented at Pin 3)	

Bus-Connection - socket/Circular connector M12, 5-pin

Pin	Configuration	External Circuitry / signal level
1	VP+5	Load resistance supply
2	RxD/TxD-N	Receive and send information -N, A Circuitry
3	DGND	Information transfer potential (measured to 5 V)
4	RxD/TxD-P	Receive and send information -P, B Circuitry
5	Shield	Shield / protective earth

Bus connection DeviceNet - M12, 5-pole circular connector

Pin	Signal	Colour	Configuration
1	Shielding	Not used	
2	V+	Not used	
3	V-	Not used	
4	CAN H	White	
5	CAN L	Blue	

Connection options, continued

Cable gland connection

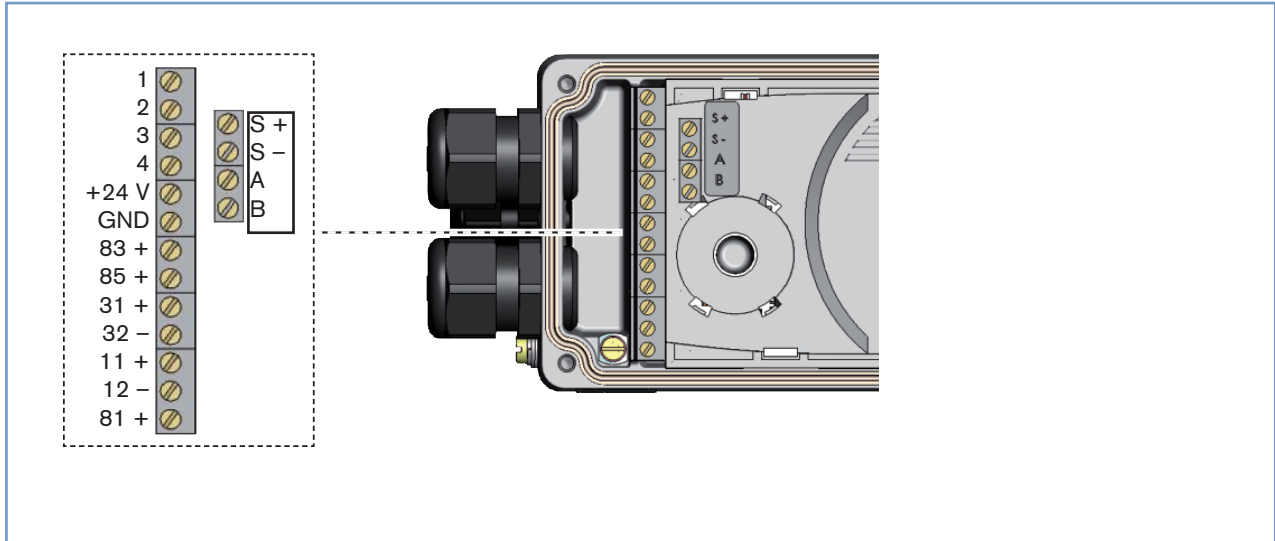

Terminal	Configuration	External Circuitry / signal level
11 +	Setpoint +	11 + + (4-20 mA or 0-10 V) Complete galvanically separated
12 -	Setpoint GND	12 - GND
81 +	Binary input +	81 + + 05 V (log. 0) 10 V (log. 1) Obtained at GND operating voltages (GND clamps)
+24 V	Operating voltages +	+24 V 24 V DC ± 10 %
GND	Operating voltages GND	GND max. Residual ripple 10 %

Optional Analogue feedback / Binary Output

Terminal	Configuration	External Circuitry / signal level
83 +	Binary Output 1	83 + 24 V / 0 V, NC / NO Obtained at GND operating voltages (GND clamps)
85 +	Binary Output 2	85 + 24 V / 0 V, NC / NO Obtained at GND operating voltages (GND clamps)
31 +	Analogue feedback +	31 + + (0/4-20 mA or 0-5/10 V) Complete galvanically separated
32 -	Analogue feedback GND	32 - GND

Terminal 1, 2, 3, 4 : NC

Optional remote version in connection with remote positioner sensor Type 8798

Terminal	Configuration	External Circuitry / signal level
S +	Supply sensor +	S + +
S -	Supply sensor -	S - -
A	Serial Interface, A cable	A A line
B	Serial Interface, B cable	B B line

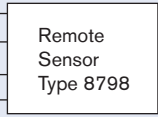

Remote sensor Type 8798

Terminal	Wire colour for cable type		Configuration	External Circuitry
	1	2		
1	white	black	Supply Sensor -	1 8791 or
2	brown		Supply Sensor +	2 8792 / 8793
3	yellow	orange	Serial Interface, B line	3 8791 or
4	green	red	Serial Interface, A line	4 8792 / 8793

Signal flow plan

Position control loop

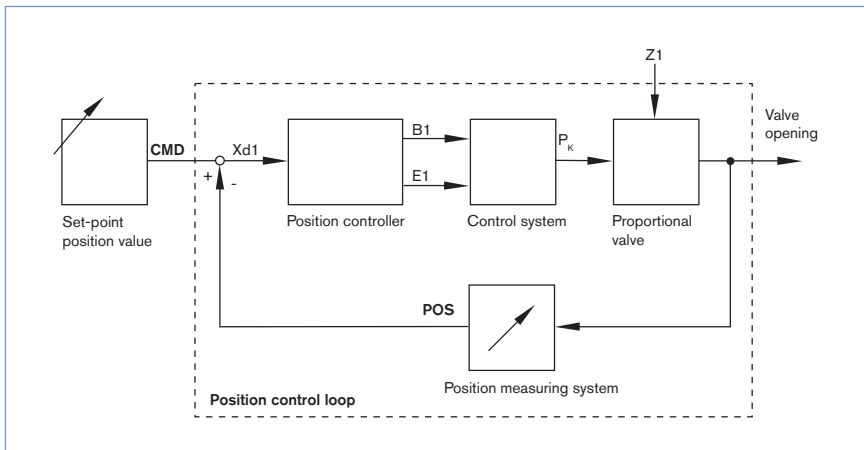

Additional software options of the SideControl Positioner Type 8792 (extract)

- Automatic start of the control system
- Automatic or manual characteristics curves selection
- Setting of the seal and the maximum stroke threshold respectively
- Parameterisation of the Positioner
- Limitation of the stroke range
- Limitation of the manipulating speed
- Setting of the moving direction
- Configuration of the binary input
- Signal range splitting on several controllers
- Configuration of analogue or 2 binary outputs
- Signal fault detection
- Safety position
- Code protection
- Contrast inversion of the display
- Parametrisable diagnostic functions* / Binary output (option)
 - Operating-hours counter
 - Path accumulator
 - Position monitoring
 - Graphical display of the dwell time density and movement range
 - Monitoring of the mechanical end positions in the armature

*You will find more diagnostic functions with a detailed description in the operating manual type 8792/93 page 148–167

Schematic diagram of SideControl, Type 8792

Without Fieldbus interface

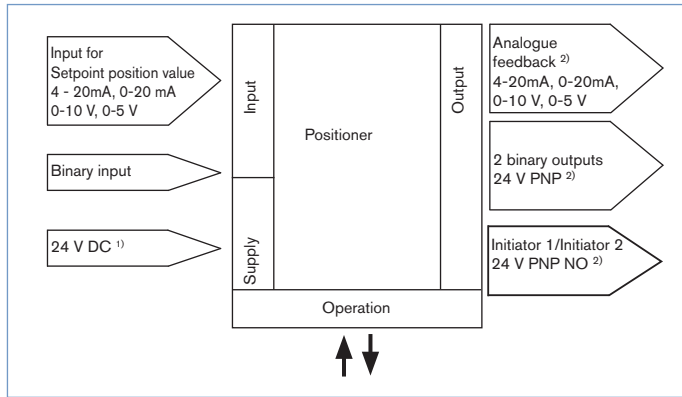

With Profibus DP / DeviceNet

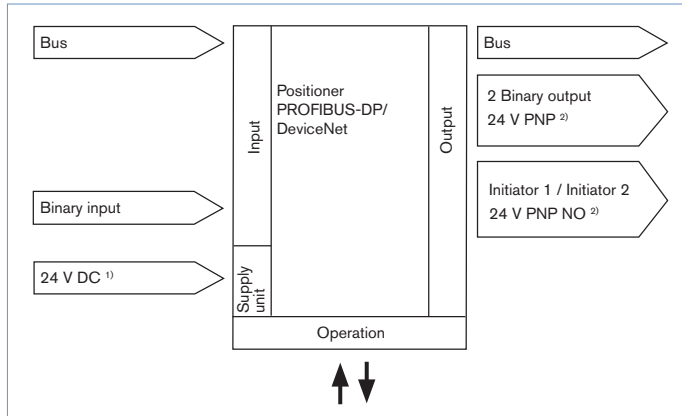

¹⁾ The operating voltage is supplied with a 3-wire unit independent from the setpoint signal

²⁾ Alternative options

Dimensions [mm]

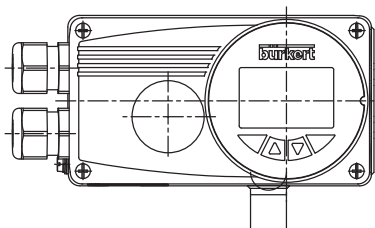
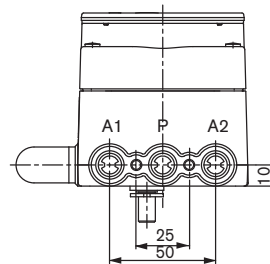
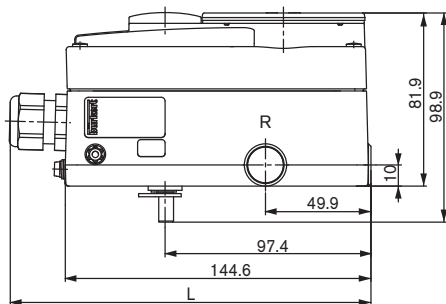
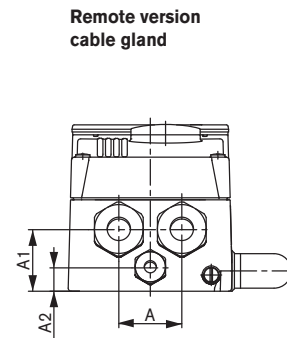
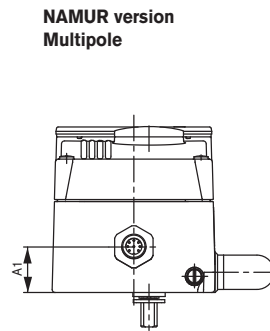
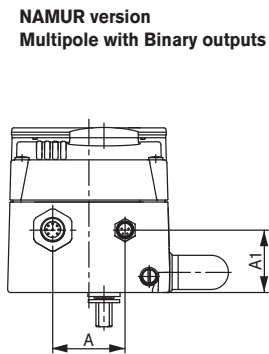
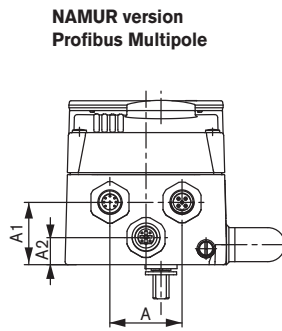
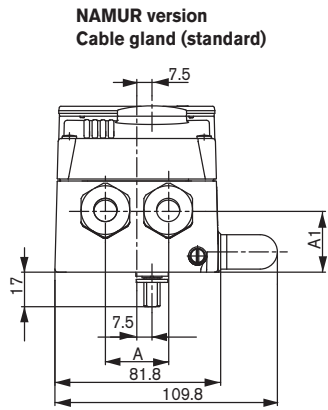

Description	L	A	A1	A2
Standard	171.1	31	30	-
PROFIBUS	157.8	36	31	13.5
Multipole Bin. OUT	157.6	36	31	-
Multipole	157.4	-	22.5	-
Remote	171.1	31	30	11.5

Dimensions [mm], continued

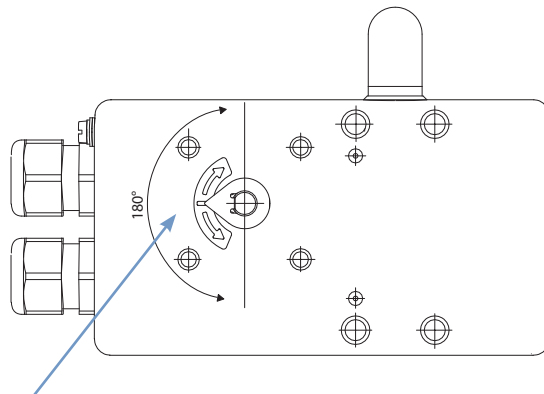

The rotation angle of the sensor must be within a range of 180°

With the valve open approx. 50%, the sensor indicator should be in this position.

Standard Version

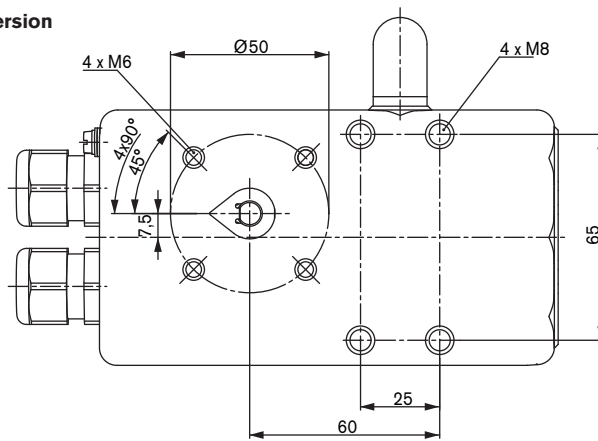

Remote version

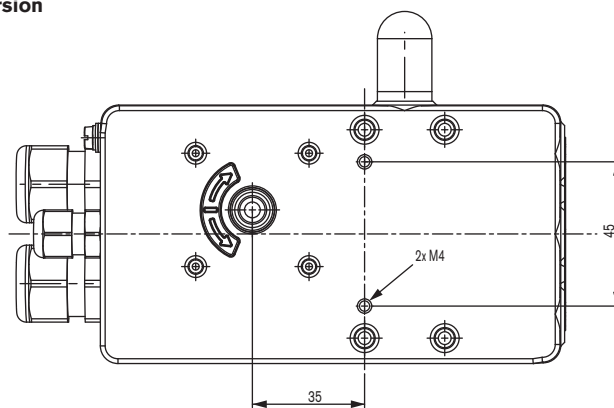

DTS 1000121137 EN Version: N Status: RL (released | freigegeben | valide) printed: 07.07.2015

To find your nearest Bürkert facility, click on the orange box → www.burkert.com

In case of special application conditions,
please consult for advice

Subject to alterations.
© Christian Bürkert GmbH & Co. KG

1505/12_EU-en_00895119